

LIFE SAFETY &amp; INCIDENT MANAGEMENT

## EST4 Emergency Communications Platform

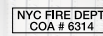

### Overview

EST4 is the premier emergency communications system from EDWARDS. Though it represents a small change in name from its predecessor, EST4's leap forward in capability is anything but diminutive. This exciting flagship system features a whole new network architecture that makes fire alarm, mass notification, and building integration easy to implement, quick to service, and secure in the face of today's cyber threats.

From its thoughtfully-crafted interface to its advanced connectivity and extensive system capacity, EST4 demonstrates that form and function are inseparable elements of good system design. It provides systems engineers with the tools they need to create projects that exceed expectations and have plenty of room to grow, all while respecting facility budgets and construction schedules. The net result is an emergency communications system equally suited to new and retrofit projects; a platform that keeps property safe and steers people clear of danger.

### Features

- **Investment-forward Platform Designed for the Future**  
Protects the past with backwards compatibility for EST3 retrofits, flexible feature set.
- **On-board Webserver**  
Remote device-independent access to system status reports.
- **Built-in E-mail and E-mail-to-SMS Messaging**  
Instant notification of specific event types sent to appropriate personnel.
- **Large Full-color LCD Touch Screen with Tactile Buttons**  
Fast, intuitive access to service and responder functions.
- **Five-color LED Indicators**  
System status at a glance, select the color needed during programming, reduces replacement part inventory, maximizes use of available infrastructure.
- **Network data, audio data, and telephone data share a single twisted pair or single fiber strand**  
Up to 75 percent less cabling, substantial cost savings in material and labor.
- **Backwards Compatibility with EST3**  
Wiring, devices, and most local rail modules are backward compatible, providing easy migration paths, economical transition to new technology.
- **Existing Systems Supporting only Network Data can also Support Voice Audio**  
Upgrades add value and extend capabilities in retrofit situations.

*continued on next page...*

## Application

From the moment the control panel is powered up it is apparent that EST4 is designed for ease of use. Its powerful user interface bears this out by allowing operators to use the system with a level of fluidity that naturally guides them through high and low level system operations with efficiency and confidence.

EST4 does this by combining the simplicity of color LCD touchscreen technology with at-a-glance programmable color display strips and tactile direct-access control buttons. These input points, together with meticulously-engineered responder and service functionality, allow EST4's interface to provide clear navigation paths, instant-access shortcuts, and context-sensitive display screens. This means that responders have quick access to vital system event information and control functions, while service personnel can dive deeply into system programming unencumbered by complicated operational routines.

EST4's LCD large touch-screen display is the window into system operation and maintenance functions. It is large enough to support a graphical tree view of the system. The tree closely matches the system's physical layout, so there's no need for look-up tables to find specific devices. This is invaluable to technicians and building service personnel who can pinpoint the location of an off-normal device with a glance at the on-screen tree.

The EST4 LCD is capable of displaying 262,144 colors, EST4's LCD display screen will display eight events without scrolling. In addition to touch-screen capability, the display assembly includes four dedicated easy-access rubber buttons for control functions most needed for emergency response.

Up to 576 tactile switches and 576 LED indicators may be mounted in a single EST4 cabinet for control and annunciation purposes. Control Display Modules (CDMs), comprise a column of programmable buttons accompanied by one or two LED indicator positions per button. Indicator-only modules comprise up to 24 indicators. Switch and indicator module LEDs can be set to any of five colors, providing an additional level of feedback.

Print-anywhere slide-in label inserts give control/display strips context with color-coded shading and other effects. They can be localized for regional language requirements, and printed on-the-fly to accommodate system changes as they are implemented.

## Remote access and notification

System access to EST4 doesn't end when the cabinet door swings shut. A web server in each EST4 panel allows authenticated users to gain access to day-to-day reporting. EST4 web services are device-independent and support all major browsers on PC and MAC operating systems, including mobile platforms – without the need for special apps or other software. Users can log into the secure EST4 web server and run system reports. Like any web page, system reports can be copied, printed, saved, and e-mailed. The system report data can also be saved in XML form and used in external spreadsheet applications for further processing.

EST4 keeps up with the fast pace of mobile computing with its built-in e-mail services and e-mail-to-text-message capabilities. These ensure that key personnel receive instant notification of relevant changes of system state. Technicians can be dispatched to the site within minutes of a service event, while safety and security personnel can arrive concurrently with first responders should the system go into alarm.

## Networking

Supporting these important interface developments is a robust system underpinned by solid networking and exceptional security. Thanks to its self-configuring network, EST4 easily deploys and configures without intervention by network administration personnel. It adapts to a wide range of network configurations, including rings, stars, redundant segment, and full mesh topology. The network even allows changes in the physical layer from copper to fiber, and employs hot-swappable network connections at control panels and annunciators. All this improves network reliability and saves money at installation time and throughout the equipment's life cycle.

The advanced technology behind EST4's network is powerful enough to drive the biggest installations

viable today. It pushes wire runs into miles, and addressable points into the many of thousands. A single IPv6 or mesh network, for example, can support copper wire runs of nearly a mile between nodes puts detection, alarm, notification, and audio into the furthest reaches of the tallest buildings and broadest campuses. Fiber optic cable handles multiple miles between nodes, while carrying all system data on a single fiber strand.

### Features (continued from page 1)

- **Self-configuring Network**  
No intervention by system admin personnel required.
- **Hot Swappable Network Connections**  
Change from copper to fiber with no system down-time.
- **480 Mbps USB Ports on Panels**  
Fast configuration updates, local printing.
- **Advanced Upload/download Protocol**  
No system down-time during updates.
- **Firewalls meet the latest Advanced Encryption Standards**  
Front-line defense against threats carried by outside networks. NIST- AES Validation #4806.
- **Extended Paging Groups**  
Audio reaches occupants based on location and movement.
- **Local and Remote Reporting**  
Generate reports on-site, at system printers, "or remotely via webserver.
- **20,000-event History**  
Invaluable timeline data for service and investigative purposes.
- **Cabinet Doors may be used for Nodes and Annunciators**  
Cabinet Doors may be used for Panels and Annunciators giving a consistent appearance, fewer cabinet parts.

# Riser Diagram

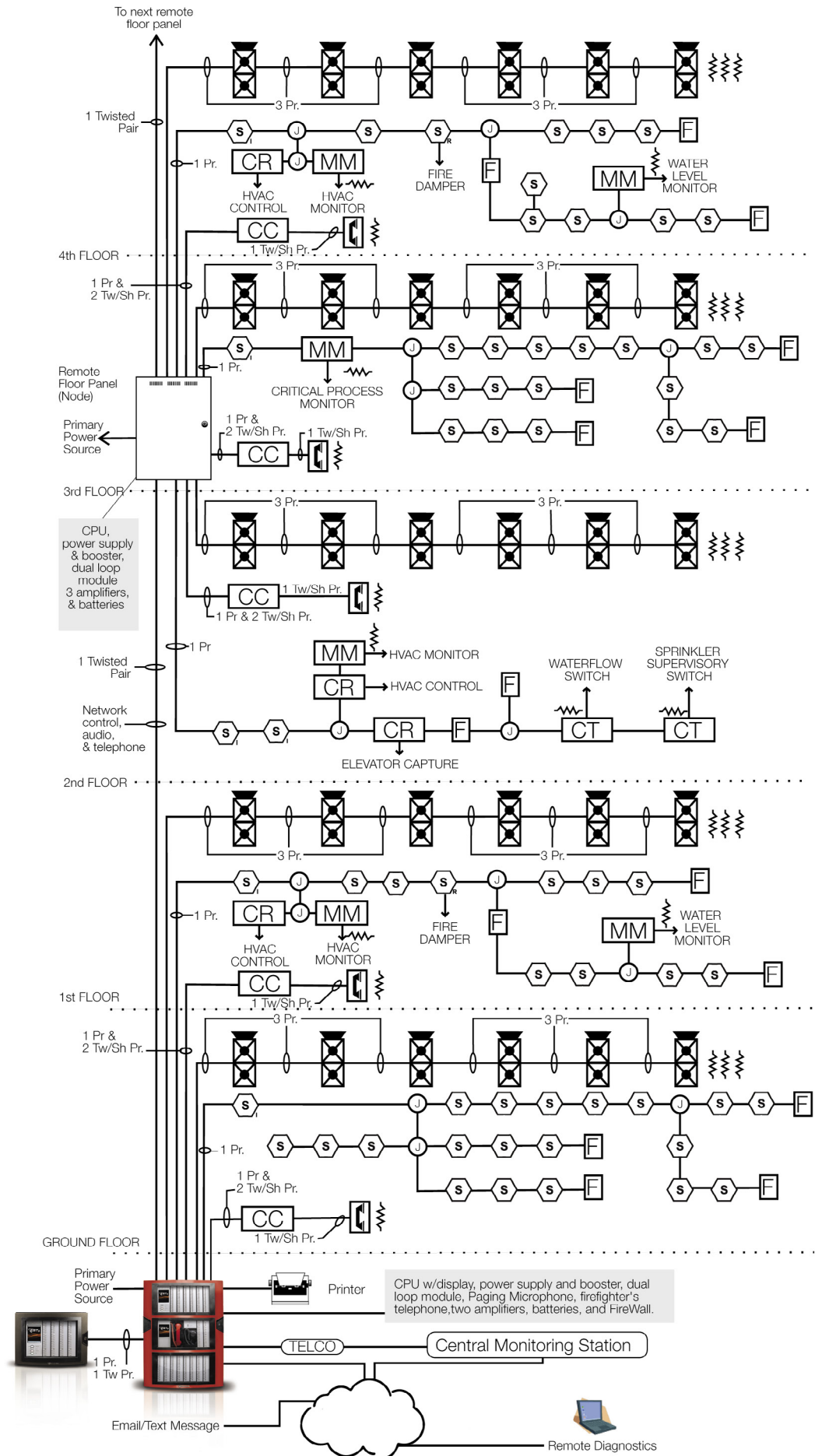

System design benefits greatly from this huge capacity. Minimal cabling requirements take scalability a step further. With EST4 a single copper pair or single fiber supports panel network data, audio data, as well as telephone data. This cuts cable counts by up to 75 percent. Meanwhile, multiple firefighter's telephones risers are accommodated on the network, which allows them to be deployed at much further distances compared with analog audio transmission methods.

Reduced network cabling not only boosts system efficiency by requiring fewer physical connections, it also saves money by reducing material and labor costs. This means that new EST4 installations benefit from lower cable counts, while retrofits may be able to be upgraded to support audio and telephones without the need to pull additional cable.

For new installations EST4 delivers flexibility. It can use twisted pair wire, Multi-mode fiber, Single Mode fiber, and even CAT5 cable. In fact CAT5 is not restricted to Class N applications. It also meets the stringent requirements of Class A, Class B, and Class X. When using CAT5, distances are not limited to 328 ft. (100 m). EST4's CAT5 support includes a solution that allow up to 3,280 ft. (1 km) of cable length.

## Cybersecurity

The security and integrity of the EST4 network is paramount to its ability to maintain systems operations in the face of outside threats. The most vulnerable point of contact for any integrated building system is where it meets the facility owner's existing TCP/IP network. Ironically it is this gateway, which enhances and expands system capability beyond the communications network, that also exposes the system to some of its most critical vulnerabilities.

To combat outside threats, every EST4 panel can deploy proxy firewalls that effectively insulate the internal fire network from external Intranet or internet connections and the malware, ransom ware, and denial-of-services attacks that may be raging beyond. The EST4 proxy firewall uses Advanced Encryption Standard (AES) encryption and secure protocols making it FIPS Pub 197 certified. The FIPS, Federal Information Processing Standards, are the most current and most advanced encryption protocols administered by the National Institute of Standards and Technology (NIST).

EDWARDS recommends the installation of robust commercial firewall between the facilities intra-net and the Internet. To further enhance network security, an optional tamper switch may be installed on EST4 cabinet doors. This alerts the system when equipment enclosures are accessed.

## Programming

EST4 is an open book for authorized programmers. Configuration data travels in both directions: it can be downloaded to the panel and uploaded to a laptop. This two-way movement of configuration files allows technicians to upload and backup programming before making changes to the system. By doing so, the tech ensures that trustworthy restore points are available at all times. Also, should the building owner change service companies, up-to-date system programming data can be retrieved with proper authorization, from the panel by the new maintenance personnel in minutes.

Adding to the integrity of panel configuration is an advanced data transfer routine that does not compromise or interrupt normal system operation. This keeps the system fully functional during configuration data exchange – logging events and executing programming during the entire process.

EST4's high-performance Configuration Utility (CU) depicts the system in a graphical tree view, which matches the system's physical layout. This provides a familiar format in which to find programming for specific devices, and also does away with the need for look-up lists when, for example, devices need to be taken out of service because of site specific activities. The programming tool also features a context-sensitive Intellisense rule editor, which checks for syntax and semantic programming errors in real time.

The EST4 Configuration Utility (CU) also makes short work of configuration downloads to the control panel. It does this through a single firmware download for all modules, and a single database download for all node databases.

EST4's on-board USB ports also make it easy to connect with external devices. The USB ports do away with special cables and RS232-to-USB conversion dongles. It allows direct high-speed connection with laptops for the exchange of configuration data at transfer rates of up to 480 Mbps. Printers can be connected to panels or remote annunciators for on-site event and report printouts.

## Audio

Nothing informs building occupants better than the spoken word, and EST4's highly intelligible voice audio ensures that those words are heard loud and clear. This high fidelity messaging, across EST4's impressive capacity of 100 channels, provides the flexibility that responders need to get messages out clearly and concisely.

EST4 live paging capabilities ensure that those messages reach the right people at the right time. In addition to standard paging functions (Page to Evacuation, Page to Alert, All Call, and All Call Minus), EST4 introduces Page to Other and Page to Emergency.

Page to Other is a quick way to reach people in stairwells and elevators, while Page to Emergency is for Mass Notification purposes. This added live paging capability allows responders to reach occupants based not only on their proximity to danger, but also based on their potential to move inadvertently towards specific danger points.

EST4 live paging also lets responders select individual paging groups as well as combinations of groups. This allows them to reach people in Alert and Evacuation zones simultaneously without having to page one group, and then page the other.

## Reporting System Snapshots

EST4 can generate an abundance of stock reports, and users may also design their own within the configuration utility. Printed reports can be generated locally at any control panel, node, or annunciator. Familiar USB connections allow for quick uploading to laptops or transfer to locally-connected printers. Reports can also be sent from any of these locations to system printers elsewhere on the network.

EST4 allows the selection of report data right down to the device level by means of pre-built templates, custom reports, or even on-the-fly using the CU configuration tool. Report content is information rich, detailed, and meaningful. This meticulous report formatting and organization results in highly understandable system overviews and useful deep dives into underlying system configuration data.

## Event History Timelines

While system status reports are invaluable for generating snapshots of important data, EST4's event history can paint a vivid picture of the system over time. A giant 20,000-event repository comprises EST4's history, which could span back as far as the system's commissioning. Half of the history can be set aside exclusively for Alarms, ensuring that records of the most important events are preserved. To support forensic investigations, up to 10,000 events can be locked and preserved so as not to be overwritten.

A large variety of pre-built history reports are available for quick access to vital records filtered by day, week, month or year. Custom reports help pinpoint records by date, time, location, device type and more. Together EST4's large history capacity and flexible history reporting serve to create vital timelines that aid in system maintenance and forensic investigations.

## Value-added Forward Migration

Easy migration paths ensure an economical transition from EST3 platforms to EST4's next-generation technology. To start, configuration data is easily transferable from an existing EST3 project to an EST4 upgrade. Hardware is also easy to migrate: all Signature Series devices, modules, and service tools are fully supported by EST4, as are Genesis series notification appliances – no rewiring is required.

Existing network cabling is also reusable for upgrades. EST4 even supports network messaging plus live paging with legacy wiring. In fact, simple twisted pair wiring, previously usable only for panel-to-panel data communications can, with EST4, support panel data, paging, as well as telephone. This means that voice audio capability may be added to a system originally wired only for network panel to panel communications – without pulling any additional wire.

EST4 also employs EST3 power supplies, audio amplifiers, MNEC equipment, CAB Series wallboxes, and most local rail modules. This makes the move to EST4 a cost-effective choice for existing installations, and new projects alike. It is a move that will benefit system efficiency and scalability now and for many years into the future.

## Agency Approvals

UL864 10th edition - UOJZ, UUKL, SYZV, UOQY

UL2017 2nd edition - FSZI

UL2572 2nd edition - PGWM

ULC-S527-11 3rd edition - UOJZ, UULK7, SYXV7

ULC-S576-14 1st edition - PGWM7

ULCS-S559-13 2nd edition - DYR7



LIFE SAFETY & INCIDENT MANAGEMENT

**Contact us**

Phone: 800-655-4497 (Option 4)

Email: [edwards.fire@carrier.com](mailto:edwards.fire@carrier.com)

Website: [edwardsfiresafety.com](http://edwardsfiresafety.com)

8985 Town Center Pkwy  
Bradenton, FL 34202

© 2020 Carrier  
All rights reserved.

---