

LIFE SAFETY &amp; INCIDENT MANAGEMENT

# Zoned Audio Amplifiers

3-ZA20A, 3-ZA20B,  
3-ZA40A, 3-ZA40B, 3-ZA95

 NYC FIRE DEPT.  
COA # 6314

 7165-1657:  
0186

## Overview

EST4 audio amplifiers take full advantage of proven digital technology to deliver highly intelligible voice audio for evacuation and Mass Notification purposes. Pre-Recorded digital messages and live paging messages are multiplexed into separate channels. Each zoned amplifier contains integrated de-multiplexing circuitry that allows eight digital audio channels, designated from the 100 system-supported channels, to be placed on the amplifier's built-in speaker circuit.

Audio channel selection is made at the control panel with all pre-recorded messages stored locally. This means there is no need to rely on network data transmissions of prerecorded messaging. The panel always plays the message for events based on the event, which ensures fast selection and reliable playback.

Audio amplifiers mount in the same enclosures as other EST4 equipment. Power for the amplifiers comes from standard system power supplies through the local rail.

Field wiring connects to removable terminal blocks on the amplifier module. Amplifiers support either 25 VRMS or 70 VRMS power limited speaker circuits. For visual signalling, each 20 or 40 watt amplifier comes standard with one 24 Vdc power limited Notification Appliance Circuit.

## Standard Features

- **Three Sizes Available**
  - 20 Watts
  - 40 Watts
  - 95 Watts
- **Simultaneous eight channel digital audio**
  - Superior sound quality
  - Each amplifier does it's own decoding
- **Speaker circuit built into amplifier**
  - Selectable for 70 or 25 VRMS output
  - Class A or Class B output models available
  - Power limited
- **3.5 amp 24 Vdc notification appliance circuit on 20 and 40 watt amplifiers**
  - Class A or Class B output models available
  - Power limited
- **Integral backup tone generator**
  - 1 KHz temporal (3-3-3) tone evac
- **Part of an end-to-end 520 Hz signaling solution**
  - UL 464/864 approved for use in sleeping rooms

## Application

EST4 zoned amplifier configurations offer improved reliability and performance. Configuration provides improved survivability in the event of wiring faults that result in a loss of signalling. In the example shown in the diagram, a fault on the system using a central backed-up amplifier disables multiple signal/page circuits, and the standby amplifier is not able to bypass the fault. With EST4, the same fault cannot occur, as there is no audio riser. All prerecorded messaging resides in the node where the amplifiers are mounted.

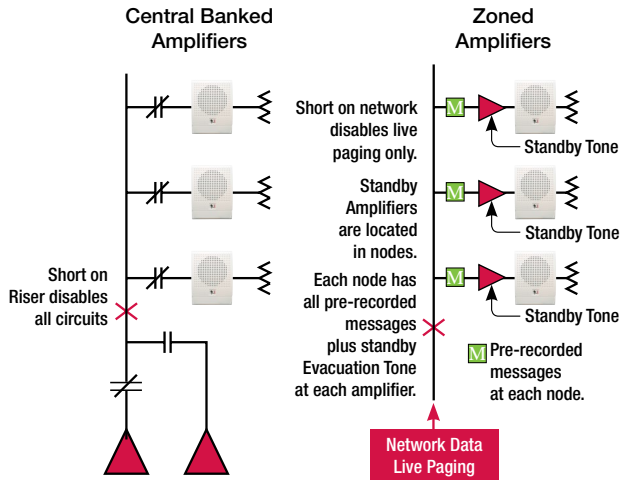

Because all EST4 nodes store their pre-recorded messages locally, programmed messages will become active when a locally generated alarm is initiated — even when a catastrophic network failure has taken place. Additionally, zoned amplifiers have integrated 1000 Hz temporal tone generators that will produce a backup signal should the main CPU suffer a catastrophic panel failure. Meanwhile, a single standby amplifier can backup any zoned amplifier in the same cabinet. These layers of redundancy provide a level of system survivability that keeps life safety measures in place, even under the harshest conditions.

EST4 easily outperforms banked audio systems and many zoned amplifier systems with its ability to simultaneously deliver up to eight of a possible 100 audio channels to each node. When using centrally-banked amplifiers, paging and alert channels typically share a common amplifier. Consequently, when paging, the alert signal goes silent in all alerted areas when a Page is issued. At the end of the Page, the alert signal resumes in the alert area. This could cause confusion because occupants will not have received the page message and do not know why the alert signal was interrupted. In zoned amplifier systems that support fewer channels, it is possible to run short of available channels — particularly in large campus networks or high rise networks where there is a need to support larger numbers of specific messaging.

With EST4, simultaneous Page, Alert, and Evacuation signal capability is engineered into the system. With 100 channels to choose from, up to eight channels can be delivered to a single node, allowing dedicated messages to be delivered to stairwells, elevator cabs, etc., while Alert, Evacuation, and Page instructions are simultaneously being sent to other areas.

Eight specific audio channels can be selected for each node. This allows messages to be automatically routed and programmed to provide specific instructions based on the alarm's location. At the same time, other areas can access and play a different eight audio messages.

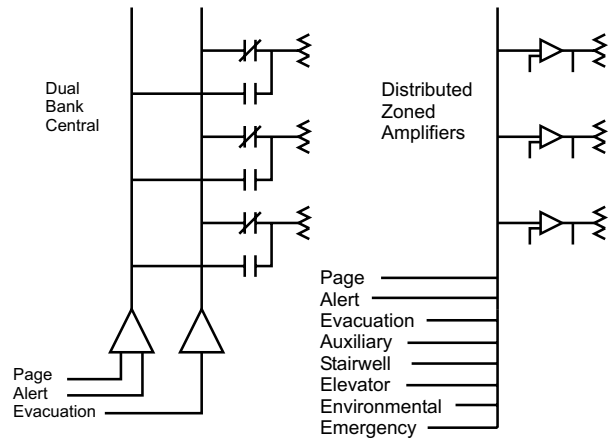

For example, with an alarm on Floor Eight, the following automatic message instructions could be given concurrently. **Note:** A Page could also be sent to any other location in the building — without interrupting any of the messages below.

**FLOOR 9 HEARS:** “A fire alarm has been reported on the floor below. Please evacuate using the stairwell.”

**FLOOR 8 HEARS:** “A fire alarm has been reported on this floor. Please evacuate using the stairwell.”

**OTHER FLOORS HEAR:** “An emergency has been reported on floor 8. Please remain in the building and await further instructions.”

**ELEVATOR:** “A fire alarm has been reported in the building. The elevator is being returned to the ground floor for emergency use. Please evacuate the building.”

**STAIRWELLS:** “Please remain calm and walk down the stairs to evacuate the building in a safe manner.”

In addition to robust paging, EST4 provides UL-listed Mass Notification, which overrides fire alarm functions. This capability allows emergency response commanders to advise building occupants of the safest action to take while an emergency is unfolding. Occupants can be instructed to leave, relocate, or seek immediate shelter, depending on the situation. This provides the flexibility for communications to mesh with the facility's risk analysis needs — without an unexpected fire alarm or general evacuation signal interfering with established emergency response protocols.

For buildings designed to allow elevators to be used for Occupant Evacuation Operation (OEO), EST4 can integrate with elevator controllers to provide specific messaging associated with the use of elevators for evacuation.

### Sleeping Areas

3-ZA Series Amplifiers are part of an end-to-end low frequency solution listed to UL 464 and UL 864. It is approved for code-compliant 520 Hz signalling in sleeping areas when used in conjunction with:

- an EST4 control panel
- a factory-supplied 520 Hz audio file
- one or more Genesis High Fidelity speakers

Consult the EST4 System Compatibility List for full details of compatible devices.

## Engineering Specification

Provide emergency audio as part of the main fire alarm control panel. The emergency audio shall contain a paging microphone and zoned amplifiers capable of delivering multi-channel audio messages. The system shall support a minimum of 100 audio channels. Transmission of live paging audio shall be over the same data network wiring as the fire panel data. The network data transmission shall be over a dedicated <single copper pair> <dual multi-mode fibers>, <dual Single mode fibers><one single mode fiber> to remote parts of the facility. Prerecorded messages shall be stored locally at each node. Transmission of prerecorded audio across the network during alarm events is not acceptable.

For systems requiring multiple locations for paging, the ability to Request/Grant/Deny page privileges shall be supported. Priorities shall be configured in software covering the operational priorities between Autonomous Control Units (ACU), Central Control Station (CCS) and Local Operators Consoles (LOCs). As a minimum the system shall consist of: Local Page, Emergency Communication,

Multiple Evacuation, Alert, Auxiliary, and General Signalling. Channels shall support hierarchical operation and be controllable from system programming. The audio system shall also provided Elevator, Stairwell and Auxiliary signalling. Systems that cause signalling devices to go silent while performing any signalling functions will not be accepted. The system shall support repeat counts of audio messages, as well as stacking of audio messages in a FIFO configuration.

The audio system zoned amplifiers must be able to operate 25 VRMS or 70 VRMS speakers. The amplifier output must be power limited, and wired in a <Class A> <Class B> configuration. The amplifiers shall source prerecorded messages locally, and shall not have to rely on network communications to receive prerecorded messaging. Should local audio be unavailable the amplifiers shall provide an integral backup 1000 KHz temporal tone generator which shall operate in the event primary audio signals are lost and the amplifier is instructed to broadcast alarm information. It shall be possible to backup multiple zoned amplifiers with a common backup amplifier.

## Technical Specifications

	3-ZA20A	3-ZA20B	3-ZA40A	3-ZA40B	3-ZA95
Agency Listing	UL, ULC, FM, CSFM				
Environmental	0°C - 49°C (32°F - 120°F) 93% RH, Non-condensing				
Frequency Response	400Hz to 4KHz @ +/- 3dB				
Output Voltage	25 VRMS or 70 VRMS				
THD (distortion)	< 7%				
Wire Size	18 to 12 AWG (1.0 to 2.5 mm <sup>2</sup> )				
Internal Tone Generator	1KHz Temporal (3-3-3) Tone (evacuation); 20 PPM (alert)				
SIGA-CC1/2 Support	10 Units, Maximum				
Standby Current	62mA for 20 and 40 watt amps; 64mA for the 3-ZA95 watt amp				
Alarm Current	1120mA	1120mA	2480mA	2480mA	5540mA
Pwr. Ltd. Audio Output Wiring Configuration	Class A or B	Class B	Class A or B	Class B	Class A or B
EOL Resistor	15K Ohms in Class B	15K Ohms	15K Ohms in Class B	15K Ohms	15K Ohms in Class B
Pwr. Ltd. 24 Vdc NAC Wiring Configuration	Class A or B (Style Z or Y)	Class B (Style Y)	Class A or B (Style Z or Y)	Class B (Style Y)	N/A
Line Resistance, Max.*	50 Ohms, Max.	50 Ohms, Max.	50 Ohms, Max.	50 Ohms, Max.	N/A
EOL Resistor Line Capacitance, Max	N/A	15 K Ohms	N/A	15K Ohms	
	0.33µF	0.33µF	0.33µF	0.33µF	
Space Requirements	1 LRM Space				2 LRM Spaces

### Maximum Speaker Circuit Distance at 0.5 dB loss\*

70 VRMS Output	3-ZA20A	3-ZA20B	3-ZA40A	3-ZA40B	3-ZA95
#12 AWG (3.2 Ohm/1000 ft pair)	4,536 ft (1,382 m)		2,268 ft (691 m)		955 ft (290 m)
#14 AWG (5.2 Ohm/1000 ft pair)	2,792 ft (850 m)		1,396 ft (425 m)		588 ft (179 m)
#16 AWG (8.0 Ohm/1000 ft pair)	1,815 ft (553 m)		907 ft (276 m)		382 ft (116 m)
#18 AWG (13 Ohm/1000 ft pair)	1,117 ft (340 m)		558 ft (170 m)		235 ft (71 m)

25 VRMS Output	3-ZA20A	3-ZA20B	3-ZA40A	3-ZA40B	3-ZA95
#12 AWG (3.2 Ohm/1000 ft pair)	579 ft (176 m)		289 ft (88 m)		122 ft (37 m)
#14 AWG (5.2 Ohm/1000 ft pair)	356 ft (108 m)		178 ft (54 m)		75 ft (22 m)
#16 AWG (8.0 Ohm/1000 ft pair)	231 ft (70 m)		116 ft (35 m)		49 ft (14 m)
#18 AWG (13 Ohm/1000 ft pair)	142 ft (43 m)		71 ft (21 m)		Not supported by 18 AWG

\* Refer to product manual for wire run calculations.



LIFE SAFETY & INCIDENT MANAGEMENT

**Contact us**

Phone: 800-655-4497 (Option 4)  
 Email: [edwards.fire@carrier.com](mailto:edwards.fire@carrier.com)  
 Website: [edwardsfiresafety.com](http://edwardsfiresafety.com)

8985 Town Center Pkwy  
 Bradenton, FL 34202

© 2020 Carrier  
 All rights reserved.

## Typical Wiring

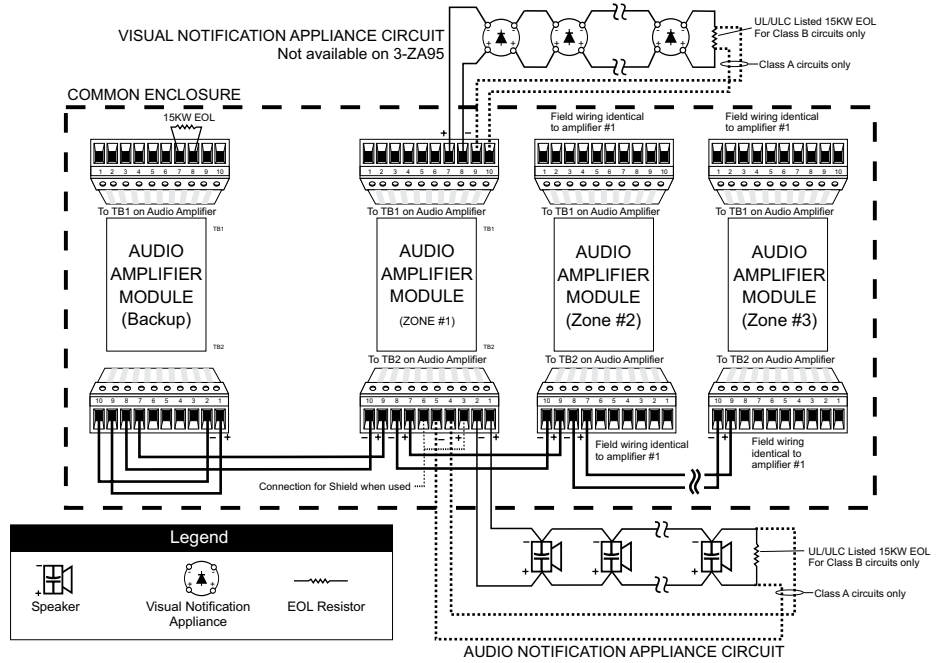

## Ordering Information

Model # (SKU)	Description	Shipping Weight
3-ZA20A	20 Watt Zoned Amplifier w/Class A/B (Style Z/Y) Audio & Class A/B (Style Z/Y) 24 VDC outputs. Add suffix "-E" for EN54 compliant versions.	1.55lb (0.7kg)
3-ZA20B	20 Watt Zoned Amplifier w/Class B (Style Y) Audio & Class B (Style Y) 24 VDC outputs. Add suffix "-E" for EN54 compliant versions.	1.55lb (0.7kg)
3-ZA40A	40 Watt Zoned Amplifier w/Class A/B (Style Z/Y) Audio & Class A/B (Style Z/Y) 24 VDC outputs. Add suffix "-E" for EN54 compliant versions.	1.55lb (0.7kg)
3-ZA40B	40 Watt Zoned Amplifier w/Class B (Style Y) Audio & Class B (Style Y) 24 VDC outputs. Add suffix "-E" for EN54 compliant versions.	1.55lb (0.7kg)
3-ZA95	95 Watt Zoned Amplifier w/Class A/B (Style Z/Y) Audio output	3.0lb (1.5kg)
4-FIL	Blank EST4 filler plate (order separately when no LED or LED/Switch module is installed on the inner door).	0.1lb (0.05kg)